

West Marine

Zephyr

VHF Marine Radio

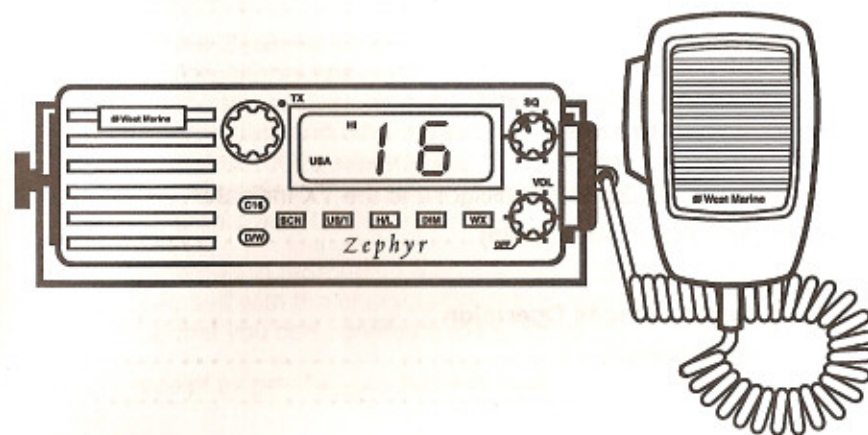

West Marine

Operating Guide

TABLE OF CONTENTS

Zephyr	1
Installation	2
Choosing A Location	2
Engine Noise Suppression	3
Antenna Considerations	3
Installing the Zephyr	3
Controls and Indicators	4
Front Panel Controls	4
Front Panel Indicators	5
Rear Panel Connectors	6
Operation	7
Dual Watch	7
Manual Tuning	7
Timed Scan (SEEK)	7
Normal Scan (SCAN)	8
Weather Scan	8
Instant Channel 16 Communications	8
US/International Channels	9
Transmitting	9
Dimming the LCD Display Backlight and the TX Indicator	10
Channels and Functions (Table)	11
Specifications	13
Maritime Radio Services Operation	14
Care and Maintenance	15
Service	16

West Marine *Zephyr*

The **West Marine *Zephyr*** VHF marine radio transceiver has been designed to give you a rugged, reliable instrument that will provide you with years of trouble-free service.

With proper care and maintenance, your **West Marine *Zephyr*** will outlast your present vessel and serve you well on-board several more. The full features and flexibility designed into this quality transceiver will prevent it from becoming obsolete regardless of changes in craft or geographic locations.

The technical excellence of the **West Marine *Zephyr*** is demonstrated by the multiplicity of uses for which it has been found acceptable by the U.S. Federal Communications Commission. The **West Marine *Zephyr*** is acceptable for compulsory use on "party boats," for use on vessels subject to the Great Lakes Radio Agreement or bridge-to-bridge requirements, for general pleasure and commercial vessels, and certain land stations in marine service.

The **West Marine *Zephyr*** is of all solid state design with conservatively rated rugged components and materials compatible with the marine environment. The transceiver utilizes a number of gaskets, sealing rings, waterproof membranes, and other sealants to effect a splashproof housing for protection of the electronics. The unit may be mounted in any number of convenient locations on your vessel by utilizing the universal mounting bracket.

You are encouraged to thoroughly read the rest of this Operating Guide to acquaint yourself with the characteristics and operation of your transceiver so that you can contribute to the longevity of your investment.

Keep your receipt as proof-of-purchase in case warranty service is required.

INSTALLATION

CAUTION: *The Zephyr will operate only with nominal 12 volt negative ground battery systems.*

It is important to carefully determine the most suitable location for your *Zephyr* on your vessel. Electrical, mechanical, and environmental considerations must all be taken into account. You must select the optimum relationship among these considerations.

Keep in mind the flexibility designed into the *Zephyr* so that you can most conveniently use your radio. Features which should be considered are:

1. The universal mounting bracket may be installed on either the top or bottom of a shelf, on a bulkhead, or for overhead mounting.
2. The REMOTE speaker jack can be used with an auxiliary speaker.
3. All connections are "plug-in" type for easy removal of the radio.

CHOOSING A LOCATION

Some important factors to consider in selecting the location for your *Zephyr*:

1. Select a location that is free from spray and splash.
2. Keep the battery leads as short as possible. Direct connection to the battery is most desirable. If direct connection cannot be made with the supplied power lead, any extension should be made with #10 AWG wire. Long extensions should use larger gauge wire.
3. Keep the antenna lead as short as possible. Long antenna leads can cause substantial loss of performance for both receiving and transmitting.
4. Locate your antenna as high as possible and clear from metal objects. The reliable range of coverage is a direct function of antenna height.
5. Select a location that does not allow the radio to be subjected to direct sunlight (including that coming through windows).
6. Select a location that allows free air flow around the heat sink on the rear of the radio.
7. Select a location well away from the ship's compass. Auxiliary speakers also should be located away from the compass.

ENGINE NOISE SUPPRESSION

Interference from the impulse noise generated by the electrical systems of engines is sometimes a problem with radios. The *Zephyr* has been designed to be essentially impervious to ignition impulse noise and alternator noise. However, in some installations it may be necessary to take measures to further reduce the effect of noise interference. All DC battery wires, antenna lead, and accessory cables should be routed away from the engine and engine compartment, and from power cabling carrying particularly high currents.

In severe cases of impulse noise interference, it may be necessary to install a noise suppression kit. Contact your West Marine Dealer for more information.

ANTENNA CONSIDERATIONS

A variety of antennas is available from a number of quality suppliers. It is recommended you draw upon the advice of your West Marine Dealer in determining a suitable antenna for your vessel and range requirements.

In general, communication range is increased by using a high-gain antenna placed as high as possible above the water line. Antennas should be located away from metal objects. Antennas should not have excessively long coaxial feed cables.

INSTALLING THE *Zephyr*

After you have carefully considered the various factors affecting your choice of location, position the radio (with the bracket, microphone, power cord, antenna and any auxiliary cables installed) into the selected location to assure there is no interference with the surrounding items. Mark the location of the mounting bracket. Remove the bracket from the radio and use it as a template to mark the holes to be drilled for the mounting hardware. Drill the holes and mount the bracket with hardware compatible with the material of the mounting surface.

Connect the red wire of the supplied power cord to the positive (+) battery supply. Connect the black wire of the power cord to ground. The power cord is equipped with a fuse to protect the radio. Use only a Six (6) AMPERE fast blow fuse for replacement. Connect the power cord to the keyed connector on the power "pigtail" (See page 6).

Connect the antenna and all other auxiliary cables and accessories.

Install the radio in the mounting bracket and connect all cables and accessories to the appropriate jacks and connectors.

CONTROLS AND INDICATORS

NOTE: For details of use of these Controls, see the OPERATION section

FRONT PANEL CONTROLS

- VOL (On/Off/Volume)** - Turns the *Zephyr* power On or Off and

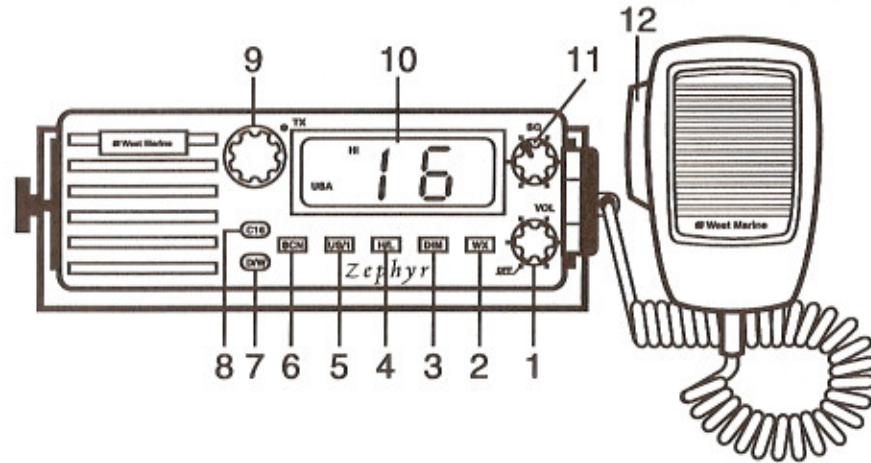

varies the audio output.

- WX (Weather)** - Used to scan only Weather Channels 0 - 9.
- DIM** - This control is used to adjust the brightness of the **LCD Panel** backlight, and the brightness of the **TX** indicator. The **LCD Panel** backlight and **TX** indicator are at the brightest level when the *Zephyr* is turned on.
- H/L (High/Low)** - Controls transmitter output power (25 Watt, where allowed, or 1 Watt). The output power is 25 Watts when the *Zephyr* is turned on.
- US/I (United States/International)** - Switches operation between US and International Channels.
- SCN (Scan)** - Used to start timed Scan (**SEEK**), switch to standard Scan (**SCAN**), and to resume scanning when stopped on a Channel.
- D/W (Dual Watch)** - Turns Dual Watch On/Off.

- C16 (Channel 16)** - Controls access to instant Channel 16 communications.
- Rotary Channel Selector** - This control is used to manually select the desired Communication Channel (01 - 28 and 60 - 88), or Weather Channel (0 - 9).
- LCD Panel** - Indicators for **DUAL**, **SEEK**, **SCAN**, **USA**, **INT'L**, **HI**, **LO**, **WX**, and **Channel Number**.

NOTE: Refer to "INDICATORS" for detailed indicator descriptions.

- SQ (Squelch)** - Eliminates the background noise when no signal is being received.
- Press-To-Talk Switch** - Press to transmit; release to receive.

INDICATORS

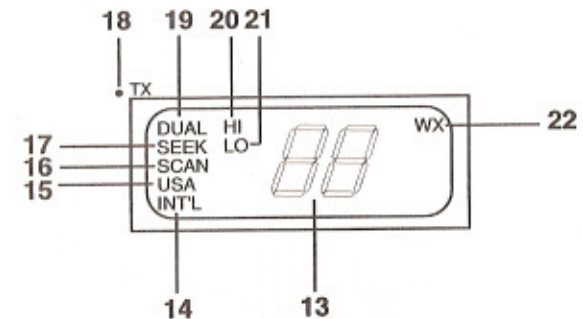

- LCD Numerical Channel Display** - Indicates Channel Number in use. Weather Channels are displayed as single digits. (Example: 0, 1, 2, 3, etc.) Communication Channels are displayed as two digits (Example: 01, 02, 03, etc.).

NOTE: LCD Status Indicators appear when status is selected by pressing the corresponding button.

- INT'L (International)** - Indicates International Channel Mode.
- USA** - Indicates US Channel Mode.
- SCAN** - Indicates Normal Scan Mode.
- SEEK** - Indicates Timed Scan Mode on Communication Channels.

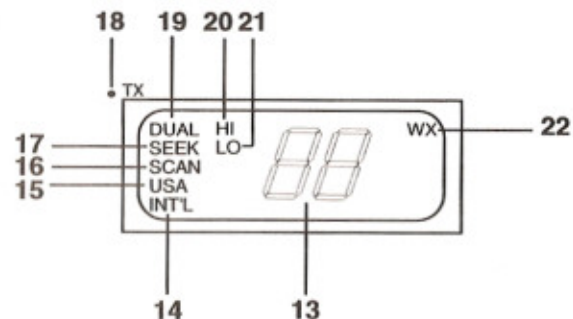

18. **TX (Transmit)** - LED lights when transmitting.
19. **DUAL (Dual Watch)** - Indicates Dual Watch Mode.
20. **HI (High)** - Indicates transmitted output is 25 Watts.
21. **LO (Low)** - Indicates transmitted output is 1 Watt.
22. **WX (Weather)** - Indicates Weather Channels.

REAR PANEL CONNECTORS

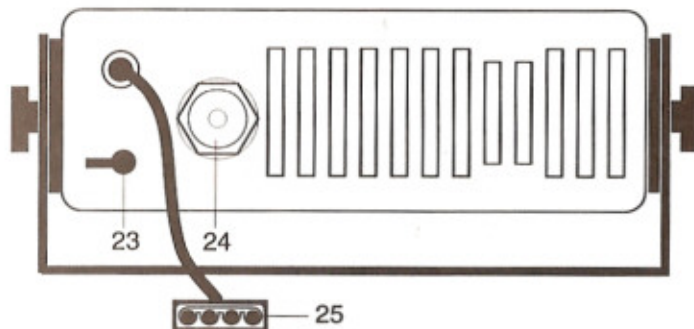

23. **Remote Speaker Connector** - An external 4 ohm, 4 watt speaker may be connected to this jack. The connecting wire must have a miniature plug.
24. **Antenna Connector** - Connect the antenna here using a type PL259 connector.
25. **DC Power "Pigtail" and Connector** - Connect supplied power cord to the keyed connector.

OPERATION

1. Turn the unit On by rotating the **VOL** control clockwise.
2. Adjust the **SQ** control counterclockwise until you hear background noise; then turn it clockwise until the noise just disappears.

DUAL WATCH

Dual Watch monitors Channel 16 for activity every two seconds while scanning or monitoring.

To activate Dual Watch, Press **D/W** while in any mode. The **DUAL** indicator will appear on the **LCD Panel**, indicating Dual Watch Mode. If a signal is received on Channel 16, the radio remains on Channel 16 until the signal ends.

Press **D/W** again to cancel Dual Watch Mode.

MANUAL TUNING

To manually select a channel, rotate the **Rotary Channel Selector** to the desired channel. Weather Channels are located on Channels 0 - 9. Communication Channels are located on Channels 01 - 28 and 60 - 88.

TIMED SCAN (SEEK)

Press **SCN** to start **SEEK** (Timed Scan).

When **SCN** is pressed for the first time after the *Zephyr* is turned on, scanning will be in the **SEEK** (Timed Scan) Mode, and **SEEK** and **DUAL** will display on the **LCD Panel**.

The radio scans for active Communication Channels except for Channel 16. (CH 16 is not included in the Scan cycle.)

Notice that Dual Watch is on automatically to cover CH 16 as well.

If there is too much activity on CH 16, and you wish to exclude it from **SEEK**, Press **D/W** to cancel Dual Watch. (**DUAL** no longer displays on the **LCD Panel**.)

In **SEEK**, the radio stops on the first active channel and stays on for 4 (four) seconds, then resumes Timed Scanning to the next active channel.

NORMAL SCAN (SCAN)

Press and Hold **SCN** until **SEEK** goes off and **SCAN** displays on the **LCD Panel**. This changes the scanning from Timed Scan to Normal Scan.

In Normal Scan, the radio will stop on the first active channel and stay until the signal is gone, or **SCN** is pressed to resume scanning.

Notice that Dual Watch is on automatically to cover CH 16 as well.

If there is too much activity on CH 16, and you wish to exclude it from **SEEK**, Press **D/W** to cancel Dual Watch. (**DUAL** no longer displays on the **LCD Panel**.)

To cancel scanning:

- Press **Press-To-Talk**, or
- Press **C16**, or
- turn the **Rotary Channel Selector**, or
- turn the power off.

NOTE: *D/W, US/I, DIM and H/L work without interrupting the Scanning Mode.*

WEATHER SCAN

To scan only Weather Channels 0-9, Press **WX**. The **WX** indicator will appear on the **LCD Panel**, indicating Weather Mode. Timed Scan (**SEEK**) will not function in Weather Mode.

Press **SCN** to switch to Timed Scanning of Communication Channels, or Press and Hold **SCN** until **SCAN** appears on the **LCD Panel**, or Normal Scanning of Communication Channels.

INSTANT CHANNEL 16 COMMUNICATIONS

To access instant Channel 16 communications, Press **C16**. This overrides the channel selected with the **Rotary Channel Selector**. The **Channel Display** will indicate the unit is on Channel 16. Press **C16** again to release the switch (Off) and the transceiver will return to the channel selected prior to accessing instant Channel 16 communications. The **Channel Display** will indicate the selected channel.

To cancel Channel 16 communications:

- Press **C16**, or
- Press **SCN**, or
- Press **WX**, or
- turn the **Rotary Channel Selector**.

NOTE: *D/W, US/I, H/L and DIM work without interrupting Channel 16 Mode.*

US/INTERNATIONAL CHANNELS

To select operation (communication and scanning) on US Channels, Press **US/I**. **USA** will appear on the **LCD Panel**.

To select operation (communication and scanning) on International Channels, Press **US/I**. **INT'L** will appear on the **LCD Panel**.

TRANSMITTING

When the power is turned on, the transmitter is set for 25 Watts (except for USA Channels 13 and 67). The **HI** indicator will appear on the **LCD Panel**, indicating 25 Watt output power. In order to comply with FCC Regulations contained in 47 CFR 80.215 (g) (3), USA Channels 13 and 67 transmit at 1 Watt regardless of the **H/L** selector setting. However, 25 Watt output for emergency use is available by pressing **H/L** while pressing the **Press-To-Talk** switch. When the **H/L** switch is released, the radio returns to the 1 Watt position.

To switch to the LO (1 Watt) position, Press **H/L**. The **LO** indicator will appear on the **LCD Panel**, indicating 1 Watt output power. The LO position should always be used for in-port or short range communications.

Press **H/L** to switch to the HI (25 Watt) position. The **HI** indicator will appear on the **LCD Panel**, indicating 25 Watt output power.

To activate the transmitter, Press the **Press-To-Talk** switch on the microphone. The **TX** LED indicator will light, indicating a signal is being transmitted. Release the switch to receive. When transmitting, hold the microphone approximately two inches from your mouth and speak clearly in a normal voice. The microphone provided with your radio is a 500 ohm dynamic type.

NOTE: *You cannot transmit on Weather Channels 0-9 or Channel 15. The Channel Number in the LCD Panel will blink to indicate these channels are "receive-only".*

DIMMING THE LCD DISPLAY BACKLIGHT AND THE TX INDICATOR

When the *Zephyr* is turned on, the LCD Panel and TX LED will be brightest. Successive presses of the DIM button will change the brightness.

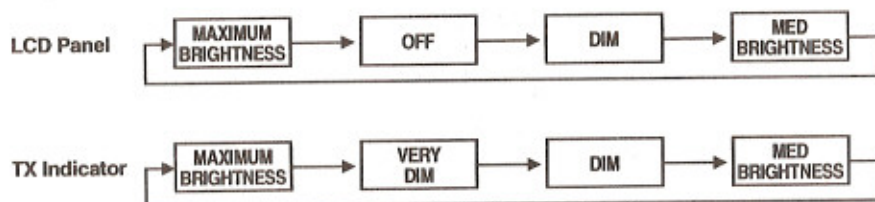

Note that the TX LED is not turned Off by the DIM button.

OPTIONAL ACCESSORIES

Flush mounting bracket for "in dash" installation.

Contact West Marine for information.

VHF FM MARINE RADIOTELEPHONE CHANNELS AND FUNCTIONS (U.S.A. CHANNELS)

CHANNEL DESIG	FREQUENCY (MHz)		TYPE OF TRAFFIC	SHIP		PERMANENT SCAN LIST
	TRANSMIT	RECEIVE		TO SHIP	TO SHORE	
WX0		163,275	NOAA Weather	RX Only	RX Only	Weather
WX1		162,550	NOAA Weather	RX Only	RX Only	Weather
WX2		162,400	NOAA Weather	RX Only	RX Only	Weather
WX3		162,475	NOAA Weather	RX Only	RX Only	Weather
WX4		162,425	NOAA Weather	RX Only	RX Only	Weather
WX5		162,450	NOAA Weather	RX Only	RX Only	Weather
WX6		162,500	NOAA Weather	RX Only	RX Only	Weather
WX7		162,525	NOAA Weather	RX Only	RX Only	Weather
WX8		161,650	Can	Weather	RX Only	RX Only
WX9		161,775	Can	Weather	RX Only	RX Only
01	156,050	156,050	VTS	Yes	Yes	
02	156,100	156,100	Port Ops	Yes	Yes	
03	156,150	156,150	Port Ops	Yes	Yes	
04	156,200	156,200	Port Ops	Yes	Yes	
05	156,250	156,250	VTS	Yes	Yes	
06	156,300	156,300	Safety	Yes	No	Coast Guard
07	156,350	156,350	Com'l	Yes	Yes	
08	156,400	156,400	Com'l	Yes	No	
09	156,450	156,450	Com'l & Non Com'l	Yes	Yes	Fish
10	156,500	156,500	Com'l	Yes	Yes	
11	156,550	156,550	Com'l	Yes	Yes	
12	156,600	156,600	Port Ops	Yes	Yes	
13	156,650	156,650	Navigational	Yes	Yes	
14	156,700	156,700	Port Ops	Yes	Yes	
15		156,750	Environmental	RX Only	RX Only	Environmental
16	156,800	156,800	Safety Calling	Yes	Yes	
17	156,850	156,850	State Control	Yes	Yes	
18	156,900	156,900	Com'l	Yes	Yes	
19	156,950	156,950	Com'l	Yes	Yes	Coast Guard
20	157,000	161,600	Port Ops	Yes	Yes	
21	157,050	157,050	Coast Guard	Yes	Yes	Coast Guard
22	157,100	157,100	Coast Guard	Yes	Yes	Coast Guard
23	157,150	157,150	Coast Guard	Yes	Yes	Coast Guard
24	157,200	161,800	Public Corresp	No	Yes	Busy Tel.
25	157,250	161,850	Public Corresp	No	Yes	Busy Tel.
26	157,300	161,900	Public Corresp	No	Yes	Busy Tel.
27	157,350	161,950	Public Corresp	No	Yes	Busy Tel.
28	157,400	162,000	Public Corresp	No	Yes	Busy Tel.
60	156,025	156,025				
61	156,075	156,075				
62	156,125	156,125				
63	156,175	156,175				
64	156,225	156,225				
65	156,275	156,275	Port Ops	Yes	Yes	
66	156,325	156,325	Port Ops	Yes	No	
67	156,375	156,375	Com'l	Yes	Yes	Fish
68	156,425	156,425	Non Com'l	Yes	Yes	Fish
69	156,475	156,475	Non Com'l	Yes	No	Fish
70	156,525	156,525	Non Com'l	Yes	Yes	Fish
71	156,575	156,575	Non Com'l	Yes	No	Fish
72	156,625	156,625	Non Com'l	Yes	No	
73	156,675	156,675	Port Ops	Yes	Yes	
74	156,725	156,725	Port Ops	Yes	Yes	
77	156,875	156,875	Port Ops	Yes	No	
78	156,925	156,925	Non Com'l	Yes	Yes	Fish
79	156,975	156,975	Com'l	Yes	Yes	
80	157,025	157,025	Com'l	Yes	Yes	
81	157,075	161,675	Coast Guard	Yes	Yes	Coast Guard
82	157,125	161,725	US Govt Only	Yes	Yes	
83	157,175	157,175	Coast Guard	Yes	Yes	Coast Guard
84	157,225	161,825	Public Corresp	No	Yes	Busy Tel.
85	157,275	161,875	Public Corresp	No	Yes	Busy Tel.
86	157,325	161,925	Public Corresp	No	Yes	Busy Tel.
87	157,375	161,975	Public Corresp	No	Yes	Busy Tel.
88	157,425	157,425	Com'l	Yes	No	Busy Tel.

VHF FM MARINE RADIOTELEPHONE CHANNELS AND FUNCTIONS (INTERNATIONAL CHANNELS)

CHANNEL DESIG	FREQUENCY (Mhz)		TYPE OF TRAFFIC	SHIP TO SHIP	SHIP TO SHORE	PERMANENT SCAN LIST
	TRANSMIT	RECEIVE				
WX0		163.275	NOAA Weather	RX Only	RX Only	Weather
WX1		162.550	NOAA Weather	RX Only	RX Only	Weather
WX2		162.400	NOAA Weather	RX Only	RX Only	Weather
WX3		162.475	NOAA Weather	RX Only	RX Only	Weather
WX4		162.425	NOAA Weather	RX Only	RX Only	Weather
WX5		162.450	NOAA Weather	RX Only	RX Only	Weather
WX6		162.500	NOAA Weather	RX Only	RX Only	Weather
WX7		162.525	NOAA Weather	RX Only	RX Only	Weather
WX8		161.650	Can. Weather	RX Only	RX Only	Weather
WX9		161.775	Can. Weather	RX Only	RX Only	Weather
01	156.050	160.650	VTS	Yes	Yes	
02	156.100	160.700	Port Ops	Yes	Yes	
03	156.150	160.750	Port Ops	Yes	Yes	
04	156.200	160.800	Port Ops	Yes	Yes	
05	156.250	160.850	VTS	Yes	Yes	
06	156.300	156.300	Safety	Yes	No	
07	156.350	160.950	Com'l	Yes	Yes	
08	156.400	156.400	Com'l	Yes	No	
09	156.450	156.450	Com'l & Non Com'l	Yes	Yes	Fish
10	156.500	156.500	Com'l	Yes	Yes	
11	156.550	156.550	Com'l	Yes	Yes	
12	156.600	156.600	Port Ops	Yes	Yes	
13	156.650	156.650	Navigational	Yes	Yes	
14	156.700	156.700	Port Ops	Yes	Yes	
15	156.750	156.750	Environmental	Yes	Yes	Environmental
16	156.800	156.800	Safety Calling	Yes	Yes	
17	156.850	156.850	State Control	Yes	Yes	
18	156.900	161.500	Com'l	Yes	Yes	
19	156.950	161.550	Com'l	Yes	Yes	
20	157.000	161.600	Port Ops	Yes	Yes	
21	157.050	161.650	Coast Guard	Yes	Yes	
22	157.100	161.700	Coast Guard	Yes	Yes	
23	157.150	161.750	Coast Guard	Yes	Yes	
24	157.200	161.800	Public Corresp	No	Yes	Busy Tel.
25	157.250	161.850	Public Corresp	No	Yes	Busy Tel.
26	157.300	161.900	Public Corresp	No	Yes	Busy Tel.
27	157.350	161.950	Public Corresp	No	Yes	Busy Tel.
28	157.400	162.000	Public Corresp	No	Yes	Busy Tel.
60	156.025	160.625				
61	156.075	160.675				
62	156.125	160.725				
63	156.175	160.775				
64	156.225	160.825				
65	156.275	160.875	Port Ops	Yes	Yes	
66	156.325	160.925	Port Ops	Yes	Yes	
67	156.375	156.375	Com'l	Yes	No	
68	156.425	156.425	Non Com'l	Yes	Yes	Fish
69	156.475	156.475	Non Com'l	Yes	Yes	Fish
70	156.525	156.525	Non Com'l	Yes	No	Fish
71	156.575	156.575	Non Com'l	Yes	Yes	Fish
72	156.625	156.625	Non Com'l	Yes	No	Fish
73	156.675	156.675	Port Ops	Yes	Yes	
74	156.725	156.725	Port Ops	Yes	Yes	
77	156.875	156.875	Port Ops	Yes	No	
78	156.925	161.525	Non Com'l	Yes	Yes	
79	156.975	161.575	Com'l	Yes	Yes	
80	157.025	161.625	Com'l	Yes	Yes	
81	157.075	161.675	Coast Guard	Yes	Yes	Coast Guard
82	157.125	161.725	US Gov't Only	Yes	Yes	
83	157.175	161.775	Coast Guard	Yes	Yes	Coast Guard
84	157.225	161.825	Public Corresp	No	Yes	Busy Tel.
85	157.275	161.875	Public Corresp	No	Yes	Busy Tel.
86	157.325	161.925	Public Corresp	No	Yes	Busy Tel.
87	157.375	161.975	Public Corresp	No	Yes	Busy Tel.
88	157.425	157.425	Com'l	Yes	No	Busy Tel.

SPECIFICATIONS

GENERAL

Channels	: Transmit 55 Receive 80 Marine 10 Weather
Controls	: On-Off/Volume, Squelch
Status Indicators	: TX LED (transmit), DUAL, SEEK, SCAN, USA, INT'L, HI, LO, and WX on LCD Panel
Channel Display	: LCD (Dual 7 segment)
Selector Switch	: Rotary Channel Selector
Buttons	: H/L (25w/1W power), DIM, US/I, WX, D/W, SCN, C16
Connectors	: Antenna, remote speaker and DC power
Size	: 2 1/5"H x 6 2/5"W x 8"L
Weight	: 2.4 lbs
Supply Voltage	: 13.8V DC negative ground
Standard Accessories	: Mounting bracket and hardware, DC power cord, microphone hanger, spare fuse
Antenna Impedance	: 50Ω, nominal
Microphone	: Rugged 500Ω dynamic element with coiled cord
Speaker	: 1.82 inch, 8Ω
Operating Temperature Range	: -20°C to +50°C (-4°F to +122°F)
Shock and Vibration	: Meets or exceeds EIA standards, RS152B and RS204C
FCC Approvals	: Type accepted under part 80 of the Rules; meets Great Lakes Agreement and party boat requirements

TRANSMITTER

Power Output	: 1 watt or 25 watt (switch selectable)
Power Requirement	: 1 watt output: 1.0A at 13.8V DC 25 watts output: 4.5A at 13.8V DC
Modulation	: FM ±5 kHz deviation (FCC designator F3E)
Hum and Noise Signal-to-Noise	: 45 dB at 3 kHz
Audio Distortion	: Less than 5% with 3 kHz deviation with 1000 Hz modulating frequency
Spurious Suppression	: -60 dB at 1 watt, -65 dB at 25 watts
Output Power Stabilization	: Built-in automatic level control (ALC)

Frequency Range : 156 to 158 MHz
Frequency Stability: : ± 300 Hz nominal

RECEIVER

Frequency Range : 156 to 163 MHz
Sensitivity : 0.25 μ V for 12 dB SINAD
0.35 μ V for 20 dB S/N
Circuit : Dual Conversion Super Heterodyne PLL
Squelch Sensitivity : 0.5 μ V Threshold
Spurious Response : 60 dB
Adjacent Channel Selectivity : 70 dB at ± 25 kHz
Audio Output Power : 4.0 watts (10% Distortion)
Power Requirement : 0.2A at 13.8V DC squelched
0.9A at 13.8V DC at maximum audio
output
1st - 16.9 MHz
2nd - 455 kHz

MARITIME RADIO SERVICES OPERATION

You are required to comply with the Rules and Regulations as set forth by the Federal Communications Commission. A complete set of FCC Marine Radio Rules may be purchased from the US Government Printing Office by requesting "Volume IV of the FCC Rules." Among the more significant rules are:

1. You must obtain a Ship's Station License by making application to the FCC on FCC Form 506. An Interim Ship's Station License may be obtained by personal appearance at your local FCC Field Office. The Ship's Station License must be posted at the station location.
2. A Restricted Radiotelephone Operator Permit (or higher grade license) must also be obtained from the FCC in order to legally operate your transmitter in international waters. Application is to be made on FCC Form 753. An interim permit is automatically granted upon submission of your application.
3. You must keep a current copy of the appropriate FCC Rules.
4. You must maintain a log book in which you record all calls and full transmitter maintenance records.
5. Your transmitter must be verified, by an appropriately licensed technician, to be in compliance with FCC requirements. This has been done at the factory for your *Zephyr*. A signed Certificate of Compliance card is included with your radio and should be kept with your log book.

6. You may not make transmitter tuning adjustments unless you are the holder of a valid first or second class commercial license issued by the FCC. Please request the assistance of **West Marine** and your nearest FCC Field Office if you need other than a Ship's Station License.

CARE AND MAINTENANCE

Your *Zephyr* is a precision piece of electronic equipment and you should treat it accordingly. Due to the rugged design, very little maintenance is required. However, a few precautions should be observed:

- If your radio has been accidentally subjected to spray or splash, you should immediately wipe it down with a soft cloth dampened with fresh water.
- If the antenna has been damaged, you should not transmit except in case of emergency. A defective antenna may cause damage to your radio.
- You are responsible for the continued FCC technical compliance of your radio.
- You are urged to arrange for periodic performance checks with **West Marine**.

SERVICE

Should you find it desirable or necessary to have service performed on your *Zephyr*, you are urged to contact **West Marine**. They will be able to assist you with complete service information.

If you require service that is within the terms of your warranty you should present a copy of your receipt to your dealer to authenticate your claim.

If you want factory service, please pack your radio in a suitable container that will provide adequate protection, enclose a note describing the problem and a copy of your receipt, and send the radio (transportation prepaid) to:

West Marine
500 Westridge Drive
Watsonville, CA 95076